

IF1 SET-UP SHEET

NAME

DATE

TRACK

EVENT

QUAL. POSITION	FINAL POSITION	BEST LAP	RACE LENGTH
<input type="text"/>	<input type="text"/>	<input type="text"/> sec	<input type="text"/> min

TEMPERATURE AIR TEMPERATURE TRACK

TRACK

TRACK SURFACE ASPHALT CARPET

TRACK LAYOUT TECHNICAL MIXED FAST

TRACTION LOW MEDIUM HIGH

GEARING

PINION GEAR

SPUR GEAR

FINAL DRIVE RATIO

DIFF SETTING

LOOSE MEDIUM TIGHT

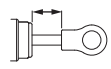

CENTER SHOCK

SPRING	OIL
<input type="text"/>	<input type="text"/>
REBOUND (%)	INNER SHIM
<input type="text"/>	<input type="text"/> mm
PISTON	LENGTH
<input type="checkbox"/> 1 HOLES <input type="checkbox"/> 1.1mm <input type="checkbox"/> 2 HOLES <input type="checkbox"/> 1.2mm <input type="checkbox"/> mm	 mm

OTHER

SIDE DAMPER

 OIL

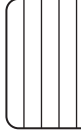
FRONT	TIRES	REAR
<input type="text"/>	TIRES	<input type="text"/>
<input type="text"/>	ADDITIVE	<input type="text"/>
<input type="text"/>	ADDITIVE TIMING	<input type="text"/>
FRONT LEFT	ADDITIVE AREA	REAR LEFT
	<input type="text"/>	
FRONT RIGHT		REAR RIGHT
		

AERO

BODY

FRONT WING

REAR WING

ELECTRONICS

MOTOR	TIMING
<input type="text"/>	<input type="text"/>
ESC	BATTERIES
<input type="text"/>	<input type="text"/>

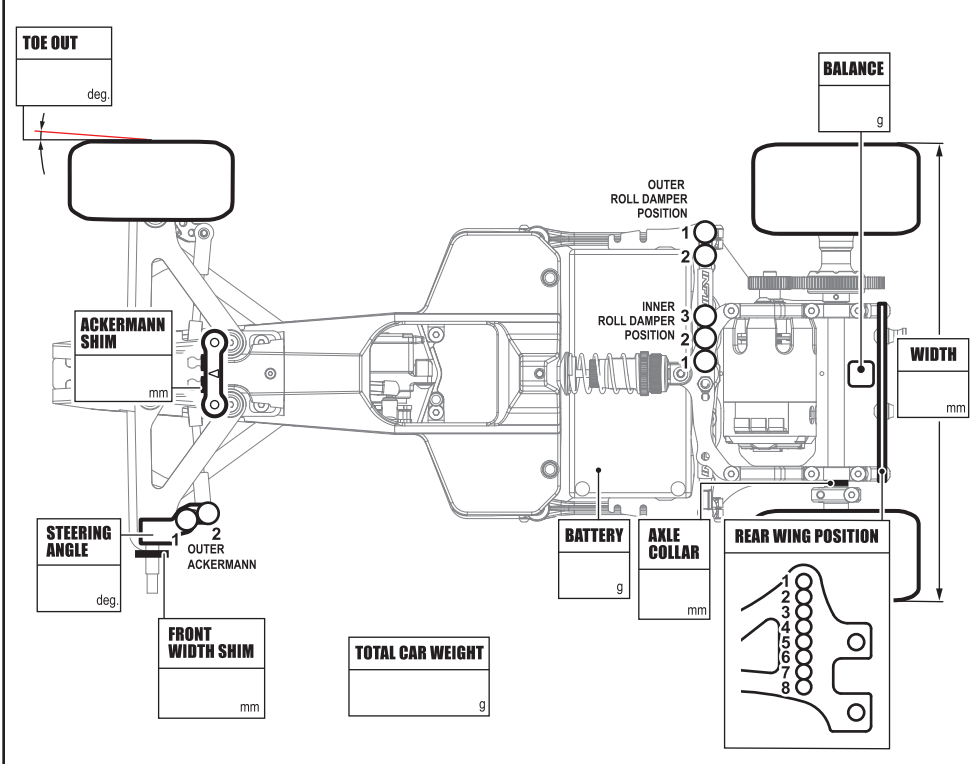
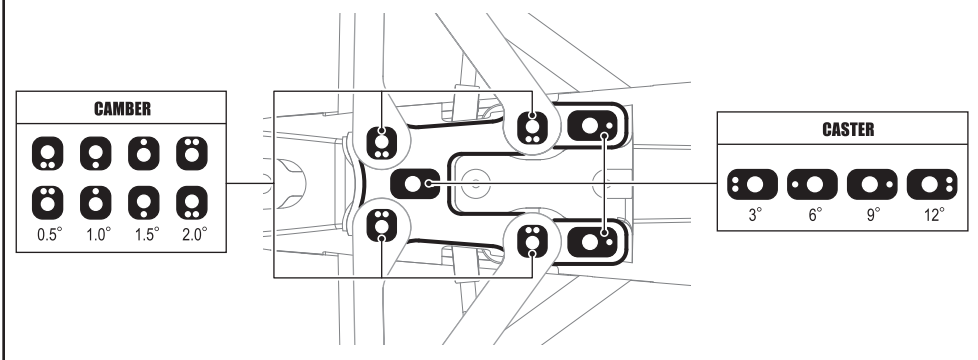
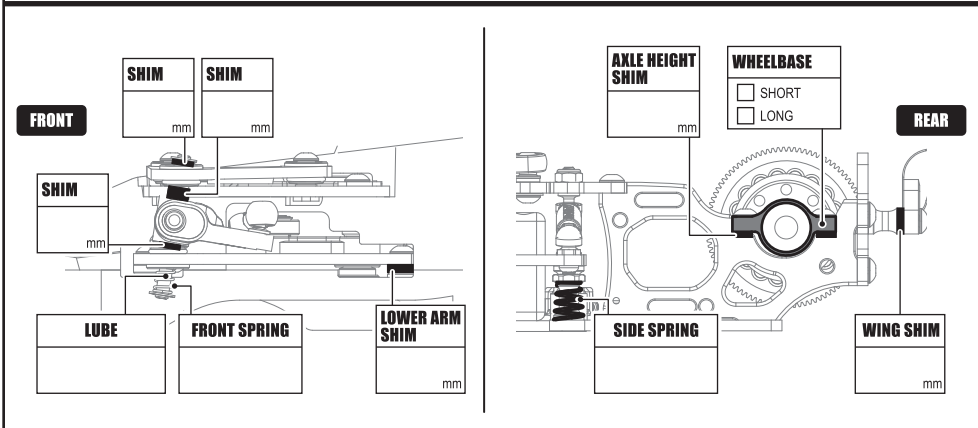
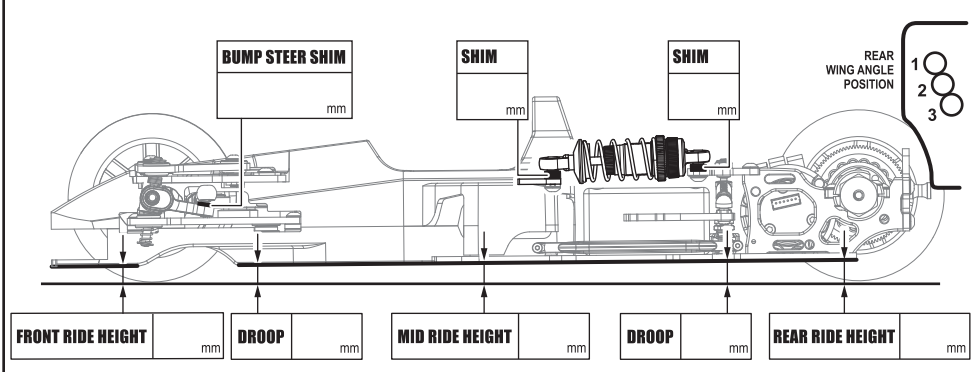

COMMENTS