

## Electronics

Motor: \_\_\_\_\_ Timing: \_\_\_\_\_

ESC: \_\_\_\_\_ Battery: \_\_\_\_\_

Servo: \_\_\_\_\_ Receiver: \_\_\_\_\_

## Gearing

Spur: \_\_\_\_\_ Pinion: \_\_\_\_\_ Final Ratio: \_\_\_\_\_

## Aerodynamics

Body: \_\_\_\_\_

Front wing: \_\_\_\_\_

Rear wing: \_\_\_\_\_

## Center Shock

Spring: \_\_\_\_\_ Oil: \_\_\_\_\_

Piston: \_\_\_\_\_ Rebound (%): \_\_\_\_\_

FP Spring: \_\_\_\_\_

Length: \_\_\_\_\_ Preload: \_\_\_\_\_

## Side Shock

Spring: \_\_\_\_\_ Oil: \_\_\_\_\_

\_\_\_\_\_ - Tires - \_\_\_\_\_

\_\_\_\_\_ - Additive - \_\_\_\_\_

\_\_\_\_\_ - Additive Time - \_\_\_\_\_

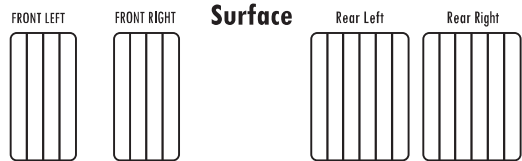

## Differential Setting

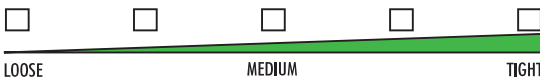

Comments

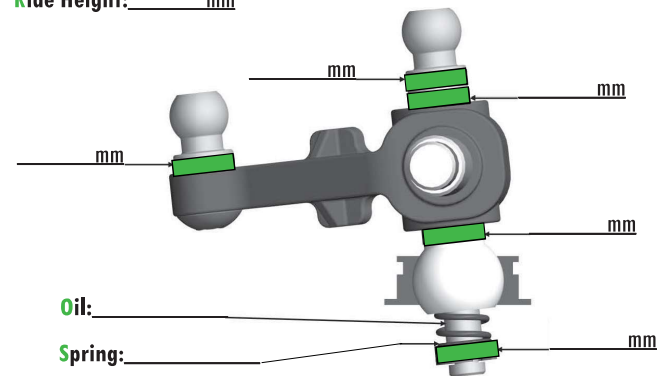
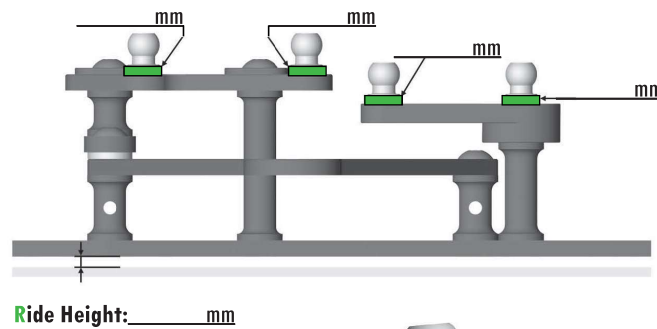
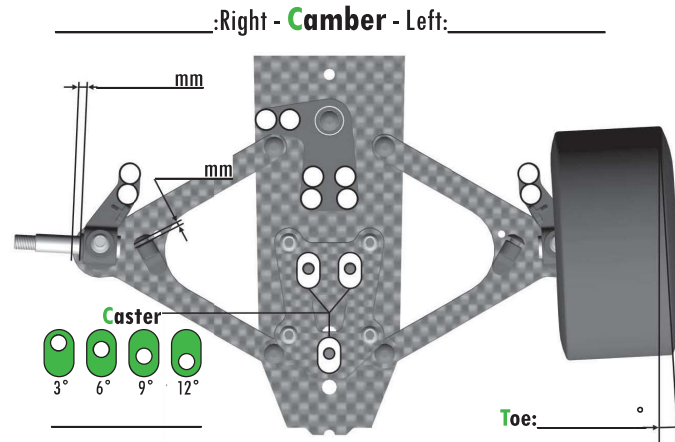

Comments

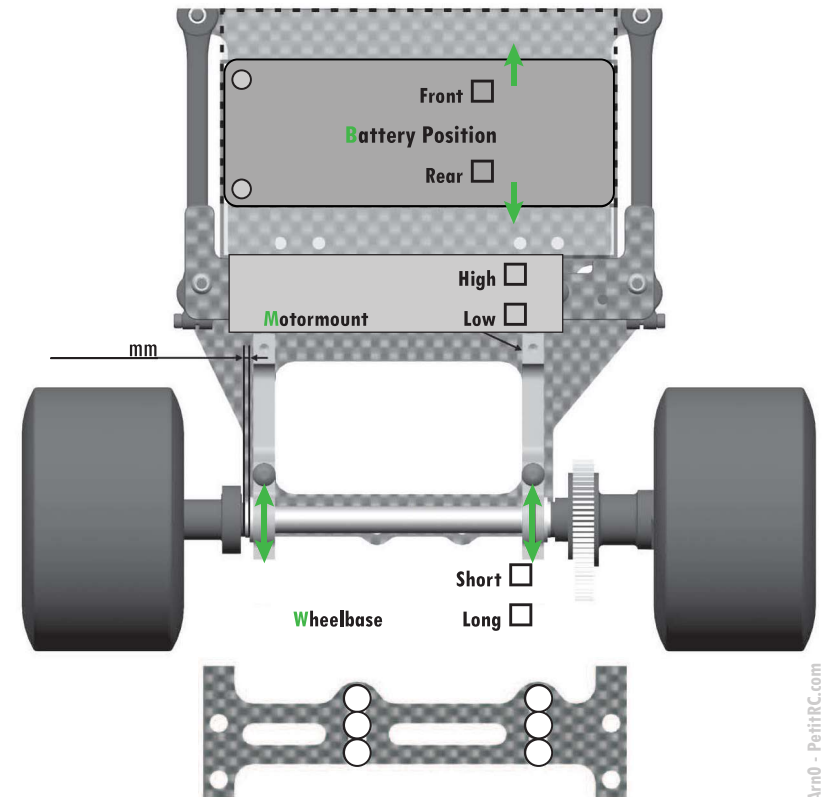
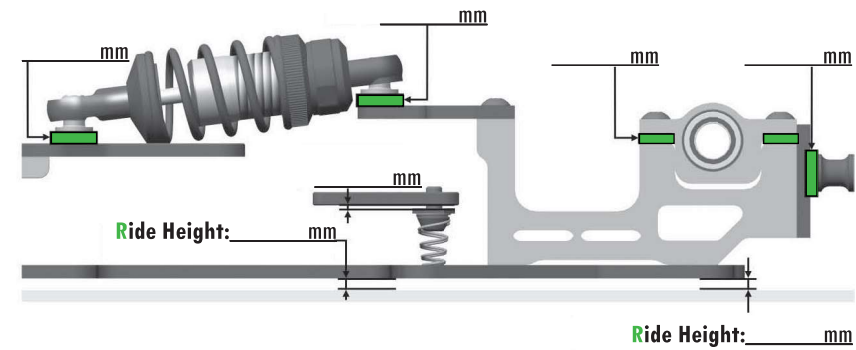

Comments