

RACE

TRACK

NAME

CITY / COUNTRY

CONTACT

DATE

QUALIFYING POSITION	BEST LAPTIME /sec	FINAL POSITION	RACE LENGTH /min
<input type="text"/>	<input type="text"/>	<input type="text"/>	<input type="text"/>

TRACK

TRACK SURFACE CARPET ASPHALT

TRACK LAYOUT TECHNICAL MIXED FAST

TRACTION LOW MEDIUM HIGH

CENTER SHOCK ABSORBER

SPRING <input type="text"/>	OIL /cSt <input type="text"/>	REBOUND % <input type="text"/>
PISTON		
<input type="checkbox"/> 3 HOLES	PISTON HOLES DIAMETER	FOAM INSERT
<input type="checkbox"/> 4 HOLES	<input type="checkbox"/> ø1.1mm <input type="checkbox"/> ø1.2mm <input type="checkbox"/> ø1.3mm	YES <input type="checkbox"/> NO <input type="checkbox"/>

ANTI-ROLL BAR

THICKNESS/mm

SIDE TUBES → OIL /cSt

SIDE SHOCK → OIL /cSt

FRONT	TIRES	REAR
<input type="text"/>	TIRES <input type="text"/>	<input type="text"/>
<input type="text"/>	ADDITIVE <input type="text"/>	<input type="text"/>
<input type="text"/>	ADDITIVE TIMING <input type="text"/>	<input type="text"/>
FRONT LEFT	ADDITIVE TREATED AREA	REAR LEFT
FRONT RIGHT		REAR RIGHT

DIFF SETTING

LOOSE MEDIUM TIGHT

GEARING

PINION /T

SPUR GEAR /T

FINAL DRIVE RATIO

ELECTRONICS

MOTOR

SPEEDO

BATTERIES

BODY

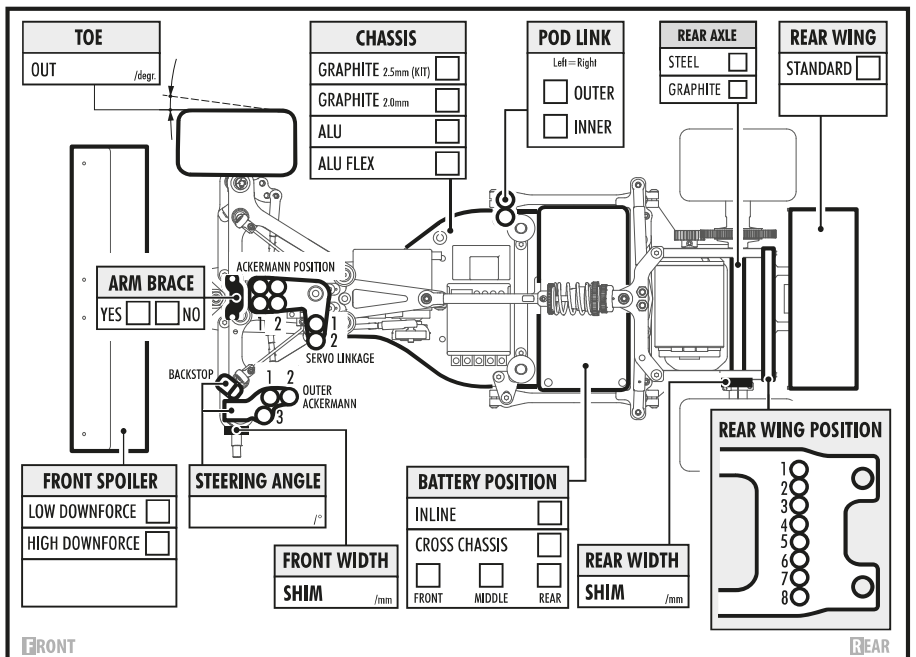
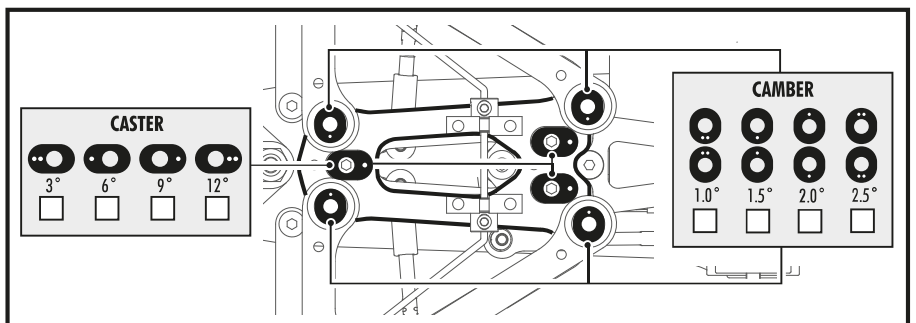
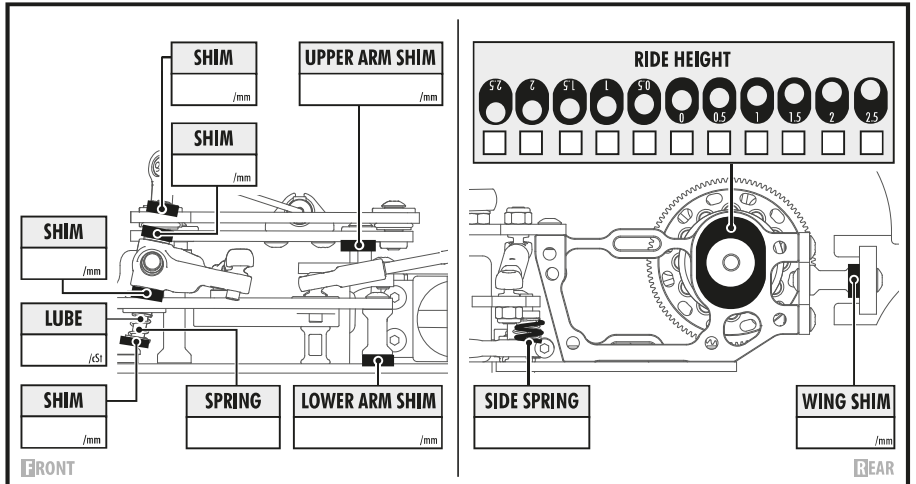
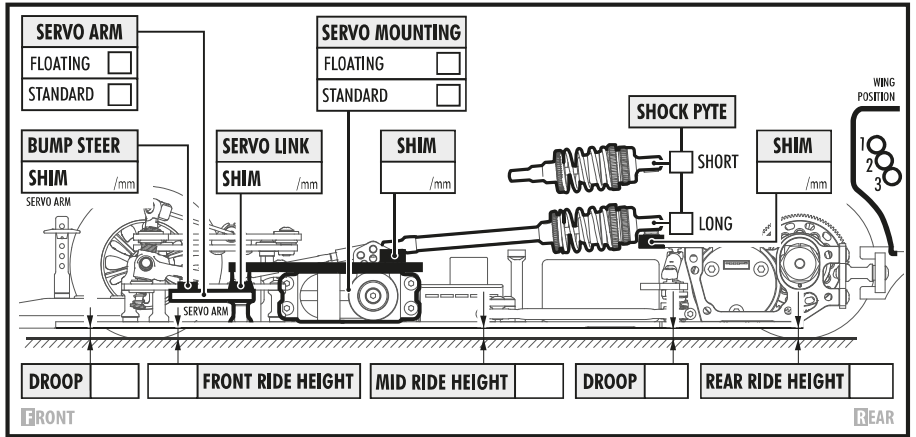

COMMENTS