

Track Info:

Size: Small Medium
 Large X-Large
Surface: Carpet Asphalt
 Indoor Outdoor
Traction: Low Medium
 High Wet
Condition: Bumpy Smooth
Temperature: Ambient Track

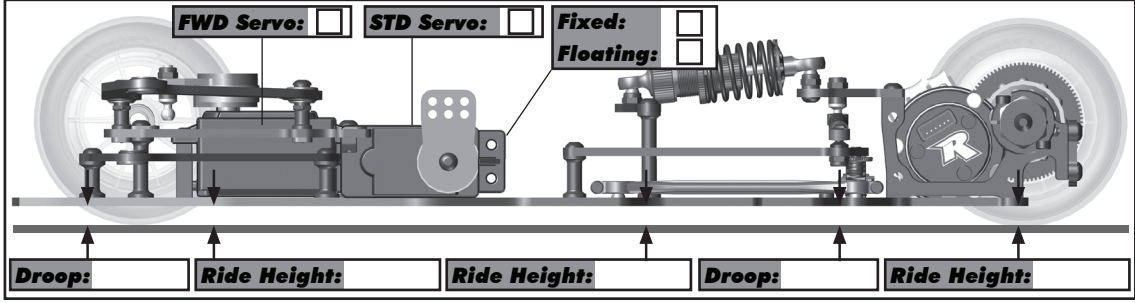

Vehicle Info:

Body: _____
Weight: _____
Notes: _____
Shock: _____
Piston: _____
Fluid: _____
Spring: _____
Rebound: _____
Pre Load: _____
Free Length: _____
Notes: _____

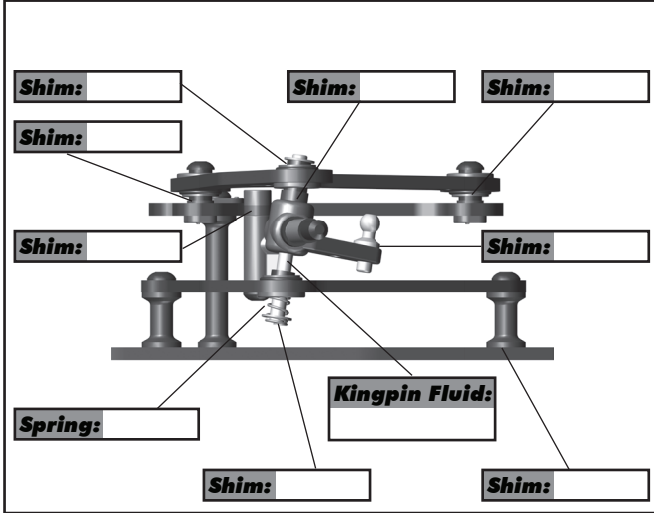

Camber: 1.0° 1.5° 2.0° 2.5°
Plastic: **Aluminum:**
Caster: 3° 6° 9° 12°
Plastic: **Aluminum:**

Diff Setting:

Loose Medium Tight

Electronics:

Radio: _____
Servo: _____
EPA: Throttle: _____ % Brake: _____ %
ESC: _____
ESC Settings: _____
Motor: _____
Timing: _____
Pinion: _____ **Spur:** _____
Battery: _____
Notes: _____

Shock:

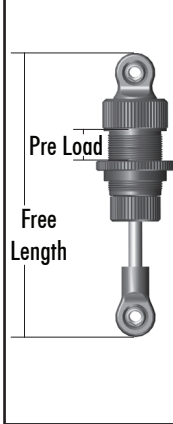

Side Spring:

Pre Load: _____
Spring: _____

Damper Tube:

Fluid: _____

Rear Wing Height:



Axle Height: 1.0 0.75 0.5 0.25 0 0.25 0.5 0.75 1.0 STD + 1mm

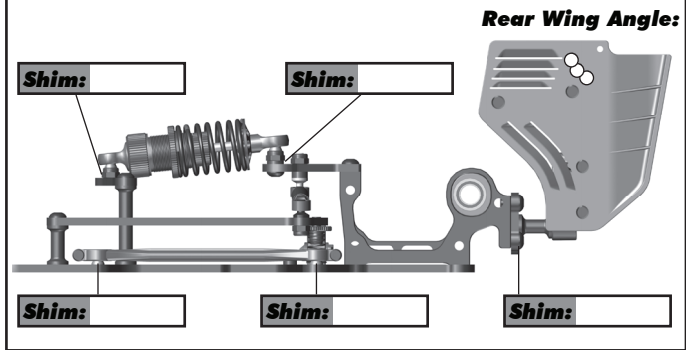

Tires:

Front Tires: _____
Front Insert: _____
Rear Tire: _____
Rear Insert: _____
Wheel (F/R): _____
Notes: _____

| | Left | Right |
|-----------------------------|----------------------|----------------------|
| Front Tire Additive: | <input type="text"/> | <input type="text"/> |
| Additive Time: | <input type="text"/> | <input type="text"/> |
| Rear Tire Additive: | <input type="text"/> | <input type="text"/> |
| Additive Time: | <input type="text"/> | <input type="text"/> |

Width: _____ **Axle Shim:** _____ **Axle Shim:** _____ **Width:** _____

